

Assembly Instructions

Tools Required: Adjustable wrench (or 1/2, 11/16, box wrench), hammer.

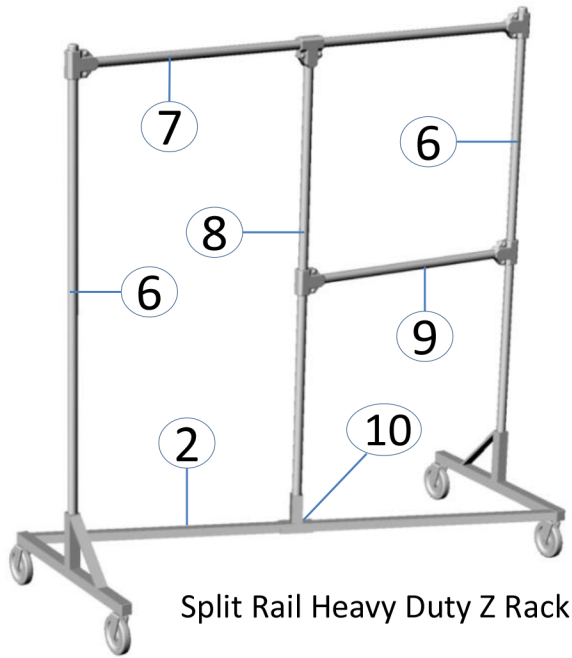

Split Rail Heavy Duty Z Rack

PARTS LIST

1. Stem Swivel Caster (x4)
2. Garment Rack Frame (x1)
3. Square End Cap (x4)
4. 7/16" Lock washer (x4)
5. 7/16" Hex Nut (x4)
6. Upright Bar (x2) 72"
7. Top Bar (x1) 60"
8. Middle upright bar (x1) 69"
9. Middle Crossbar (x1) 29 1/4"
10. Flange Tee (x1)
11. 3/8" Carriage Bolt (x10)
12. 1"x1" Brace Clamp (x5/ 10 pcs.)
13. 3/8" Kep Nut (x10)
14. Round End Cap (x2)

Assembly Instructions – Frame

1. Insert Casters (1) into frame (2) and Tighten 7/16" lock washer (4) and 7/16" hex nut (5).
2. Insert Flange Tee (10) on top of frame (2) then insert middle upright (8) and Upright Bars (6).
3. Insert Square end caps (3) into Frame.

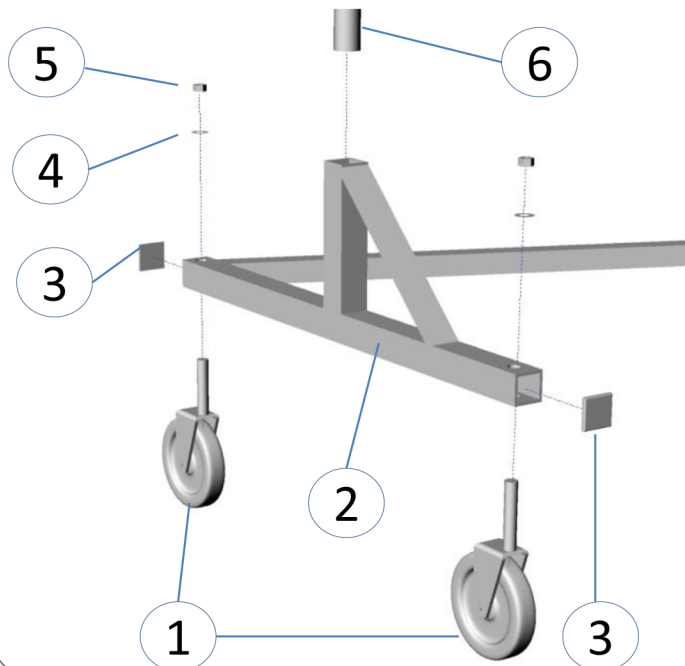

Assembly Instructions – Brackets

1. Attach top rail bar (7) and Upright Bars (6)(8) using brace clamps (9), 3/8" carriage bolts (11) and 3/8" Kep nuts (10).
2. Repeat sequence for Middle Crossbar (9) by securing Clamp assemblies (9,11,13) to Upright Bars (6,8).
3. Insert round end caps (11) into upright bars (6).

