

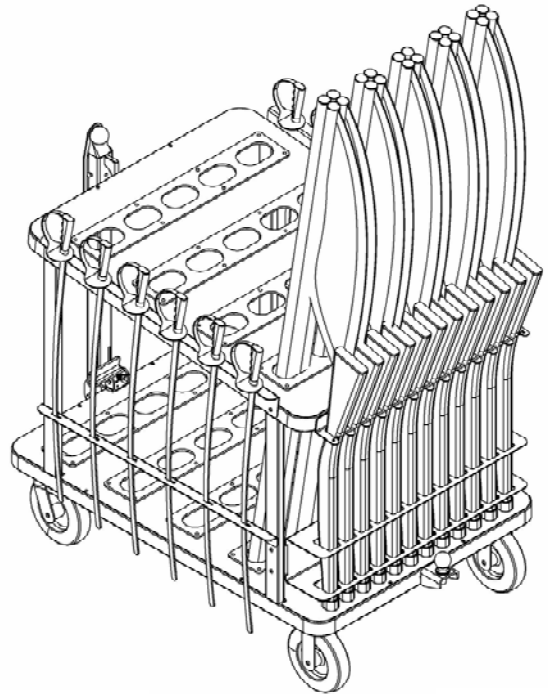

STAGE RIGHT

PRODUCT INFORMATION PACKET

PRODUCT NAME: Flag Cart

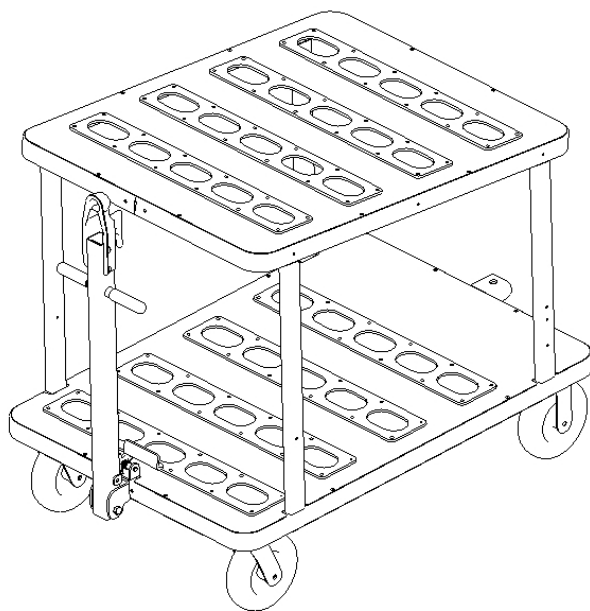

**Shown with optional equipment*

KEEP INFORMATION PACKET FOR FUTURE REFERENCE

Table of Contents

- Introduction.....1
- General Safety Rules.....2
- Symbols.....3
- Technical Specifications.....4
- Instructions.....5
- Maintenance.....8
- Customer Service Information.....8

Introduction

The StageRight Flag Cart has been designed and manufactured with safety, performance and dependability as top priorities, making it easy to operate and maintain.

The care you give your Flag Cart will greatly determine your satisfaction with its performance and service life. Careful study of this manual is encouraged to obtain a thorough understanding of your new Flag Cart and its functions and maintenance.

If your manual becomes lost or destroyed, StageRight will gladly provide you with a new copy. Should you require additional information or assistance, please feel free to contact us at 1-800-438-4499.

BECAUSE STAGERIGHT CORPORATION MAINTAINS AN ONGOING PROGRAM OF PRODUCT DEVELOPMENT AND IMPROVEMENT, WE RESERVE THE RIGHT TO MAKE IMPROVEMENTS IN DESIGN OR CHANGES IN SPECIFICATIONS WITHOUT INCURRING ANY OBLIGATIONS TO INSTALL THEM ON UNITS PREVIOUSLY SOLD.

General Safety Rules



WARNING!



READ AND UNDERSTAND ALL INSTRUCTIONS.

Failure to follow all instructions listed below may result in serious personal injury.

SAVE THESE INSTRUCTIONS

- **Stay clear of all pinch points.** Keep hands away from pinch points.
- **Make sure the hitch coupler is properly engaged before towing Flag Cart.**
- **The Flag Cart is for Off Road use only.** The cart is intended to be used at practice/game fields. Do not attempt to haul cart on main roadways.
- **Do not haul Flag Cart at speeds exceeding 5 mph.** Hauling at excessive speed may cause the cart to lose control thereby causing an accident or serious injury.
- **Do not ride on the Flag Cart.** The cart is intended to haul equipment only. Failure to adhere by this rule can cause serious personal injury.
- **Set brakes on the Flag Cart when left unattended.**
- **Do not climb on the Flag Cart.** The cart is not a toy and should not be played on.
- **Save these instructions.** Refer to them frequently and use them to instruct others who may use the Flag Cart.
- **Read the Product Information Packet.** Failure to read the information packet is considered a misuse of this equipment.
- **Become familiar with all caution and warning decals affixed to the field equipment before use.**
- **Never cover or deface caution/warning labels.**

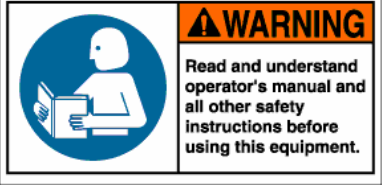
Symbols

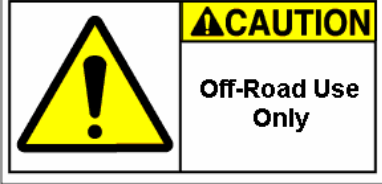
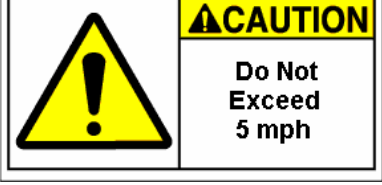
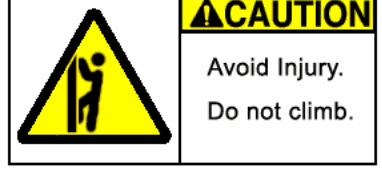
	<p>Safety Alert: Precautions that involve your safety</p>
	<p>Read The Operator's Manual: To reduce risk of injury, user must read and understand operator's manual before using this product</p>
	<p>Pinch Point Warning Label: Failure to keep hands away from pinch points will result in personal injury</p>
	<p>For Off-Road Use Only Warning Label: Field equipment is not intended or designated for roadway travel</p>
	<p>Hauling Speed Warning Label: Do not exceed 5 mph when hauling field equipment.</p>
	<p>Do Not Climb Warning Label: To reduce risk of injury, do not climb on field equipment.</p>

StageRight Corporation Technical Specifications

Flag Cart

Part #	Description	Weight
360161	Flag Cart	225 lbs
108958	Saber Add-On	20 lbs
108959	Rifle Add-On	18 lbs

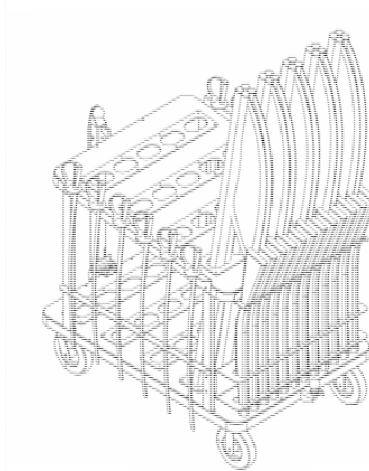
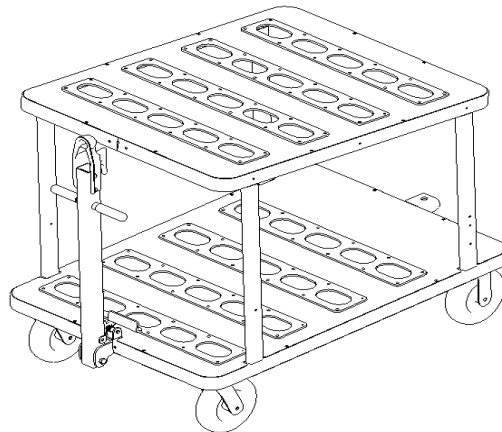

Storage Capabilities with add – on features:

80 flags
12 sabers
12 rifles

Construction, Finish and Hardware

- Constructed of ASTM specified steel
- HDPE flag locator plates
- “Softex” grip material or equivalent
- Non – marking foam filled casters
- Polyurea coated hitch latch
- Zinc-plated hardware
- Baked on powder coat finish

Instructions

1

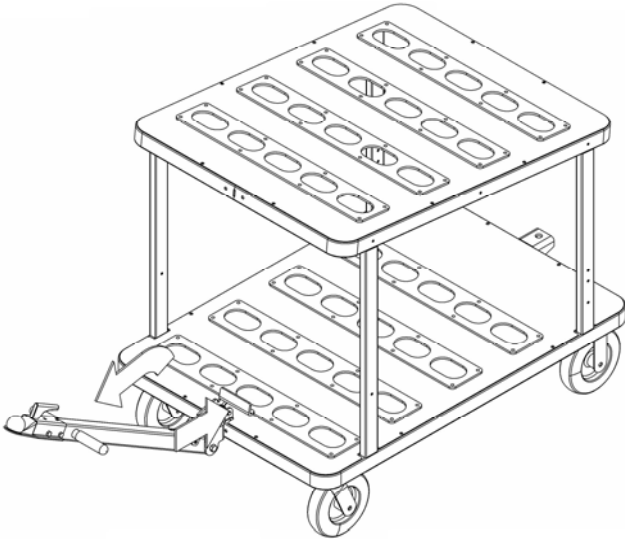

To unlock the hitch from the upright/locked position, disengage the locking mechanism by depressing the hitch latch. This allows the hitch tube to lower to its hauling position so it can be moved manually or with a hitched vehicle. Hitch has handles for manual pulling.

2

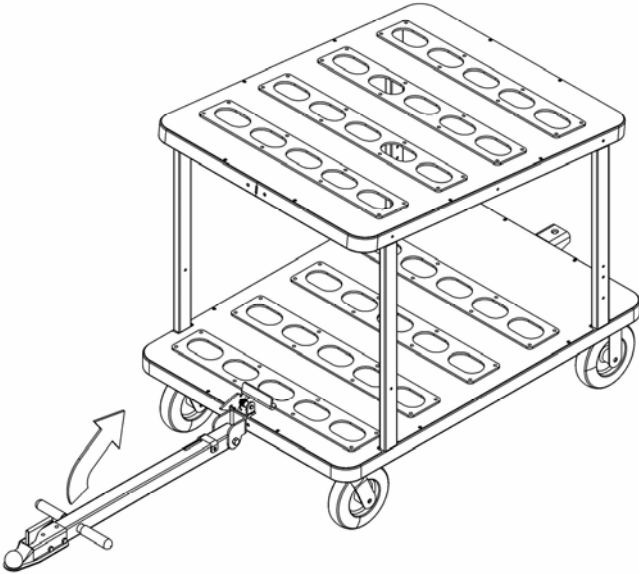

Raising the hitch tube back up will cause it to automatically lock in the upright position for storage.

3

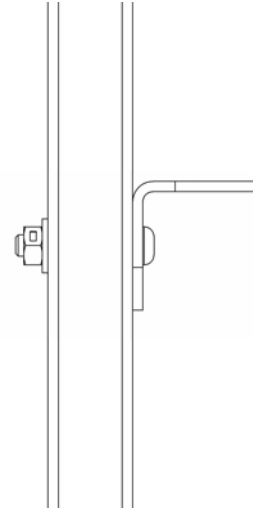
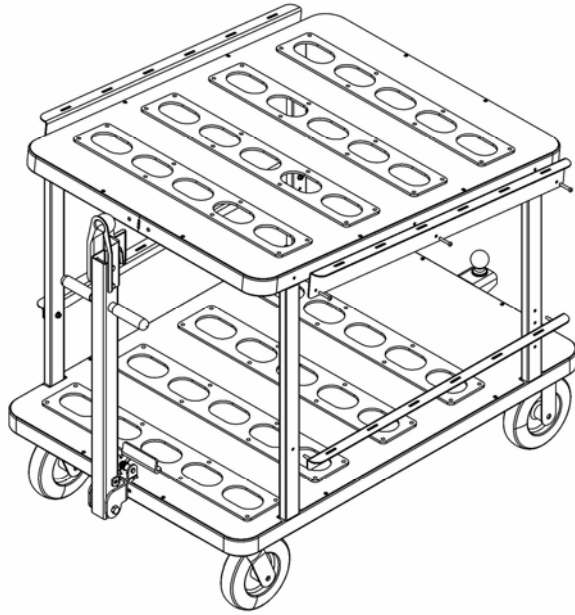

To attach optional Saber Brackets use the supplied bolts, nuts and washers to bolt thru the frame. Three bolts are used to attach the top brackets while two bolts are used to attach the bottom brackets.

4

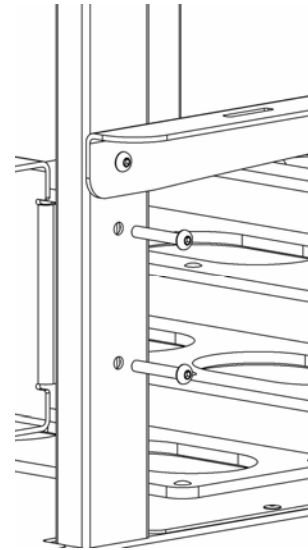
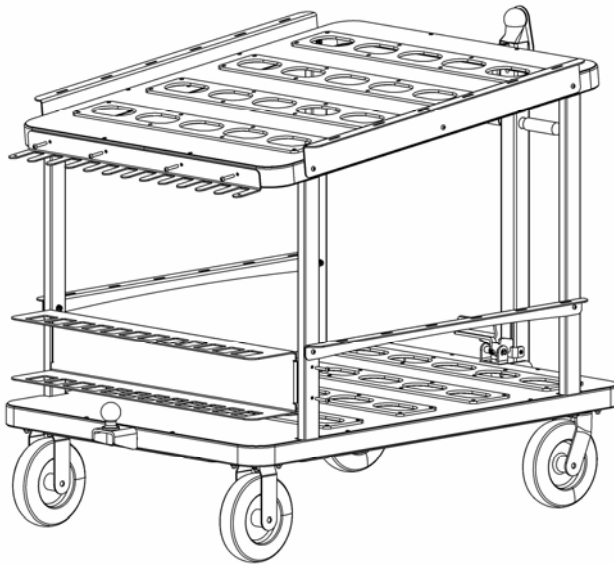

To attach optional Rifle Brackets use the supplied bolts, nuts and washers to bolt thru the frame. Four bolts are used to attach both the top and bottom rifle brackets.

5

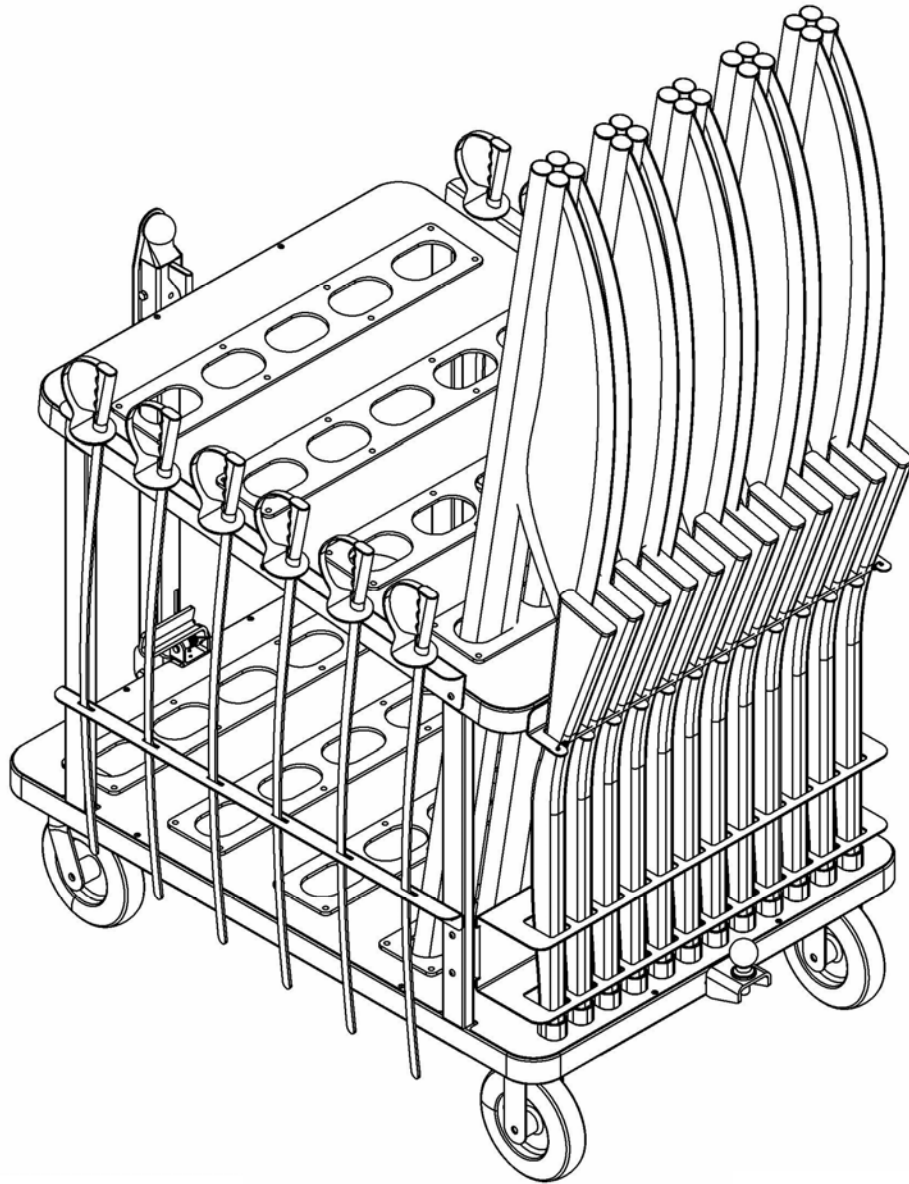

The Flag Cart equipped with the add-on features is capable of hauling 80 marching band flags, 12 sabers and 12 rifles. Use the supplied bungee cord to secure rifles before moving cart.

Maintenance



WARNING!

Read and Understand All Maintenance Procedures

Failure to follow all procedures listed below may cause serious injury and a decrease in the equipments functional existence.

- **Frequently check to see that all fasteners are properly engaged.**
- **Touch up paint can be used to cover any scratches or blemishes sustained through use.**
- **Replace any damaged equipment with genuine StageRight parts.** Failure to do so may result in unsafe equipment and/or personal injury.

Customer Service

For parts or service contact StageRight Corporation. When ordering parts be sure to provide all relevant information available including the name and part number of the equipment purchased. This information is located on the cover of this product information package. Hours of phone service are Monday thru Friday from 8:00 a.m. to 5:00 p.m. Eastern Standard Time. Customers can phone toll-free at (800) 438-4499 or mail:

StageRight Corporation
495 Pioneer Parkway
Clare, Michigan 48617
www.stageright.com



SET UP IN MINUTES



STURDY, WITH NO TOOLS REQUIRED



UNSURPASSED CUSTOMER SERVICE

StageRight Corporation
495 Pioneer Parkway
Clare, MI 48617
Toll-free: 800-438-4499
Phone: 989-386-7393
Fax: 989-386-3500
Email: info@stageright.com
Web: www.stageright.com